

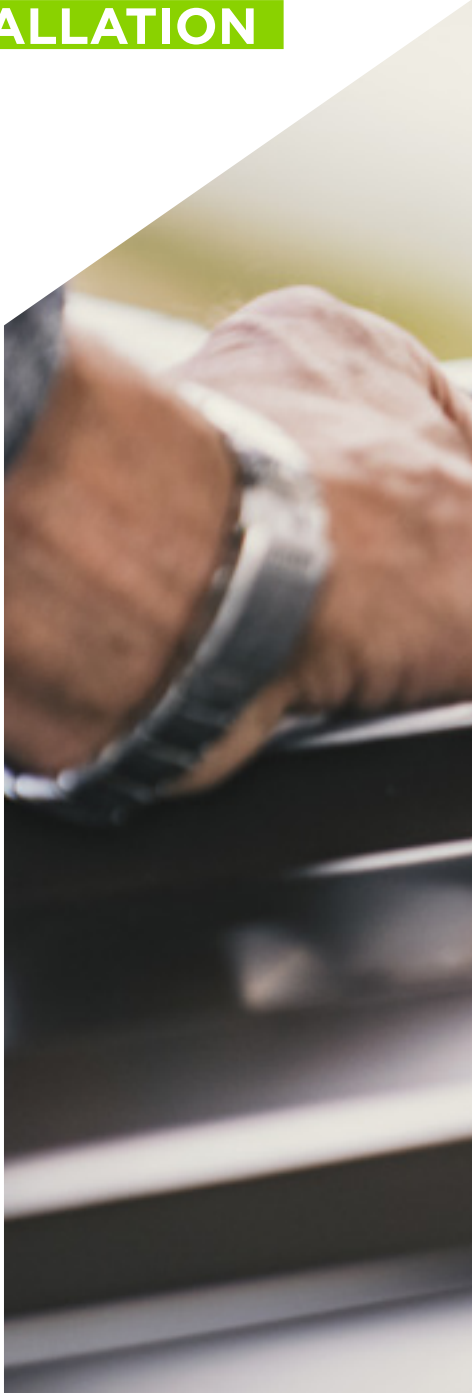

COMPOSITE BATTEN CLADDING INSTALLATION GUIDE



INSTALLATION
INSTRUCTIONS



PLEASE READ

Please take a moment and read thoroughly before you start your installation

As for any external cladding system it is recommended that you check with the planning office within your local council to ensure whether you need to submit a planning application. Note that Composite Batten Cladding is a class B fire rating and so not suitable for external cladding above the height of 18m on residential buildings.

The diagrams and instructions outlined in this guide are for illustration purposes only and are not meant or implied to replace a licensed professional.

SAFETY

When dealing with any type of construction project, it is necessary to wear appropriate safety equipment to reduce risk of severe injury. When handling, cutting, and installing, the following safety equipment is recommended at the very least: gloves, a respiratory protection mask, long sleeves, long trousers, and safety glasses.

TOOLS

Standard woodworking tools may be used. It is recommended that all circular saw blades have carbide tips and that all fixings are stainless steel.

STORAGE

Bison Composite Batten Cladding should be stored on a flat surface either fully supported or on timber bearers at maximum 400mm spacing.

PLANNING

Careful layout planning and preparation is required before starting installation to ensure the best possible cladding effect of your project. Consideration for how the boards will finish at corners, window & door reveals can ensure a better finish, reduce wastage, reduce rip cuts or additional joints. We recommend drawing out a site plan of your proposed project to minimize errors.

CONSTRUCTION

WPC products are NOT intended for use as columns, support posts, beams, joist stringers or other primary load-bearing members. WPC products must be supported by a code-compliant substructure. While WPC products are great for retrofits, they CANNOT be installed on existing cladding boards.

VENTILATION

WPC products CANNOT be directly installed onto close boarding like OSB or MDF. It must be installed onto a substructure, so there is adequate and unobstructed air flow under the cladding to prevent excessive water absorption.

A minimum of 25 mm (1 inch) of continuous net free area under the cladding surface is required for adequate ventilation on all wall cladding, so air can circulate between adjacent members to promote drainage and drying.

Our composite batten cladding gives the on-trend style of real Cedar or Larch but also offers the robust and low-maintenance benefits that you get from a quality composite building material





MAIN PARTS FOR THE INSTALLATION

ITEM	USAGE	IMAGE
Cladding Plank (2700mm x 219mm x 26mm)	Main wall Covering	
Corner (2500mm x 56mm x 51mm)	Used at external corners and window/door reveal	
Edge Board (2500mm x 140mm x 12mm)	Used for deeper window and door reveals	
Steel Drip Trim (2000mm x 20mm x 30mm x 15mm)	Installed at window and door heads	

Note: Cladding can be installed on either timber, composite or metal supporting joists

WALL CLADDING SCREWS

ITEM	USAGE	IMAGE
Cladding Screw (M4 x 25 mm)	Used to fix cladding boards to wood joists	
Coloured Screw (M4 x 35 mm)	Used to fix cladding boards or corners when fixing head is visible	

Note: Alternative screws may be required when installing to metal supporting joists

**SWATCHES
AVAILABLE**

Can't decide on a colour?
Order a sample box via our website
at www.bisonsystems.co.uk



JOIST INSTALLATION

1. Before installation



1. Before installation, make sure the supporting wall is flat and sound. Packing shims can be used to ensure levels. A breathable vapour barrier should be installed behind joists to prevent water penetration.

2. Supporting joists

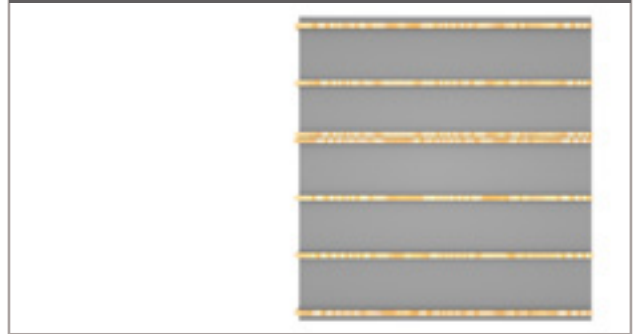

2. Supporting joists (not supplied) should be a minimum of 25mm deep and 38mm wide. Fix joists to the wall at maximum of 450mm spacing with relevant anchor fixings.

3. Spacing

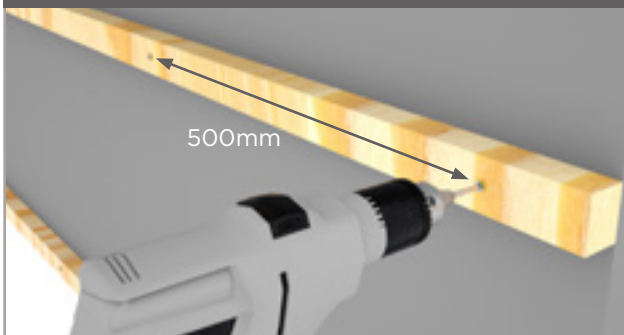

3. The spacing between anchors should be no more than 500mm.

4. Butt jointing

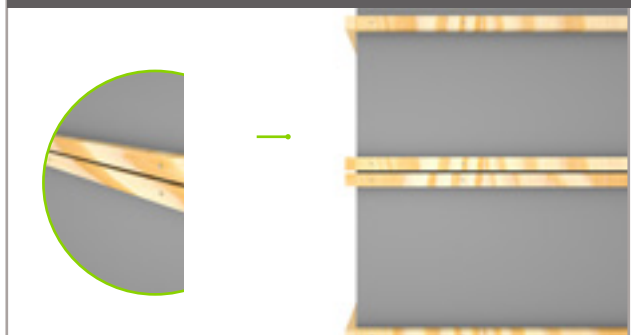

4. When butt jointing two lengths of cladding (runs over 2700mm), it is important to install double joists so that each board is secured to an independent joist.

CLADDING PLANK INSTALLATION

1. Fixing the first plank



1. The first cladding plank will first need to be fixed with a 35mm colour head screw through the low 'valley' of the cladding profile.

2. Additional fittings*



2. Then fix the same cladding plank through the recessed screw groove on the lap edge using a 25mm long plain fixing screw. * see note at end

INSTALLATION INSTRUCTIONS

CLADDING PLANK INSTALLATION (continued)

3. Lap the 2nd cladding

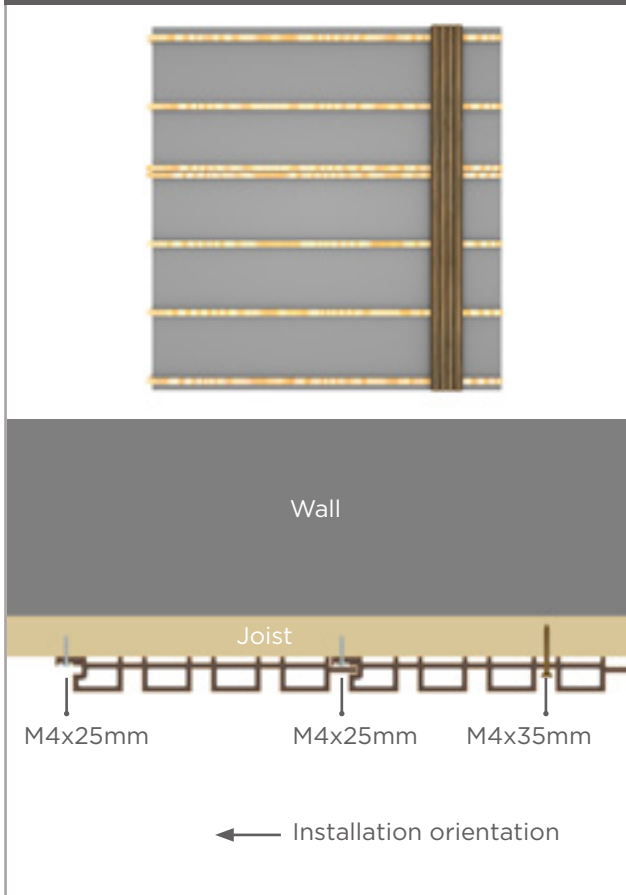

3. Lap the second cladding plank into the first. Secure the cladding to the joist using the 25mm long fixings screw through the recessed screw groove on the lap edge.

6. Repeat steps 1-6



6. Repeat installation steps 1-6 around the corner on the next wall.

4. Repeating with 8mm gap

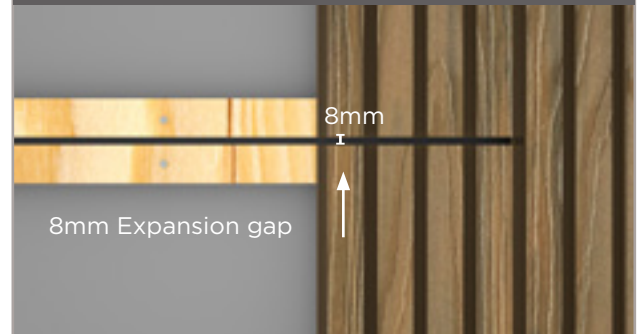

4. Continue the installation by repeating step 3.

IMPORTANT: An 8mm expansion gap should be left at butt joints between two adjacent cladding planks.

5. Finishing on a corner



5. When finishing on a corner, cut the last cladding plank to suitable width and fix to a joist using a 35mm long colour head screw through the low valley of the cladding profile.

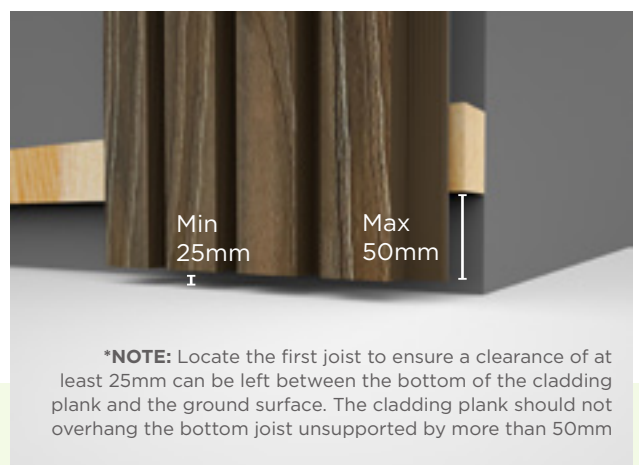

***NOTE:** Locate the first joist to ensure a clearance of at least 25mm can be left between the bottom of the cladding plank and the ground surface. The cladding plank should not overhang the bottom joist unsupported by more than 50mm

EXTERNAL CORNER INSTALLATION

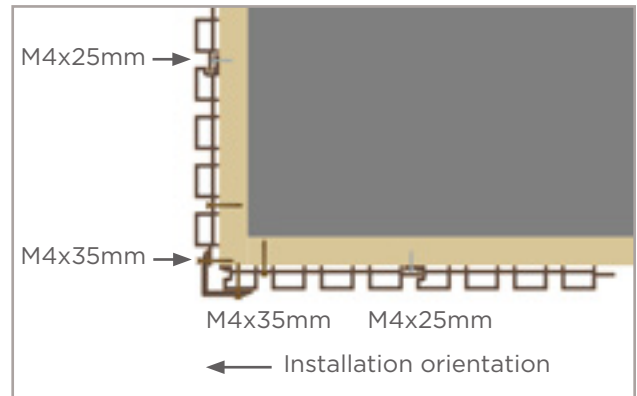
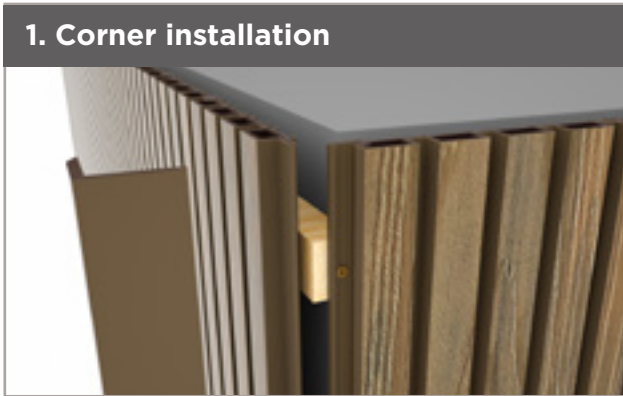

1. Install L Corners vertically at external corners using high quality adhesive sealant and 35mm long colour head screws spaced at 900mm centres.

***NOTE:** L Corners can also be used to terminate a run of cladding mid-wall.

WINDOW AND DOOR HEAD DETAIL



1. When cladding above windows or doors, a colour coded steel drip trim should be installed to the joist to carry water away from the building. Cut the trim to the width of the window and fix it using 25mm screws prior to installing any cladding. The spacing between screws should be 300mm maximum.

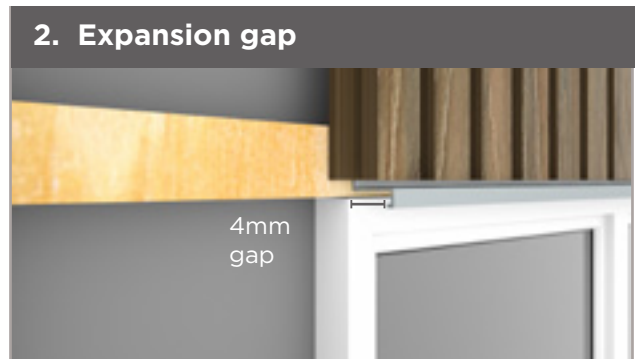

2. Leave a 4mm expansion gap between the bottom of the cladding plank and the drip trim

WINDOW/DOOR REVEAL FINISH 1 (shallow reveal)

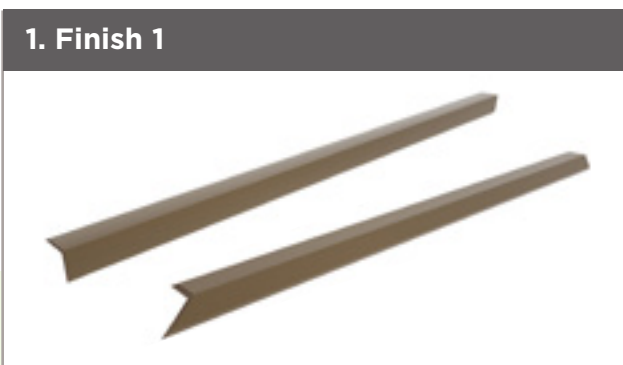

1. For shallow window or door reveals it may be possible to just use the L corners on the two verticals either side of the window. At the base of the window an L corner can be used only if there is not an existing sill in place. Ensure adjoining corners are mitre cut for best finish.

***NOTE:** Always pre-drill L corner prior to screw fixing

INSTALLATION INSTRUCTIONS

WINDOW/DOOR REVEAL FINISH 2 (deep reveal)

1. Deeper reveals

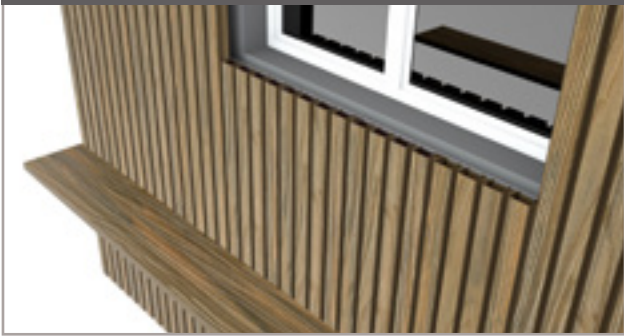

1. For deeper window reveals Edge Boards can be cut to length and to a suitable width so that it finishes flush with the front of the cladding planks.



2.



2. Secure the edge boards to vertical sides of window and also to underside (if sill not present or long enough) with both structural adhesive sealant and 35mm colour head screws.



3. L corners can also be used in addition to the edge board frame, to frame the window if desired.



COLOUR FINISHES

Available in 2 colour finishes
Order a sample box via our website
at www.bisonsystems.co.uk

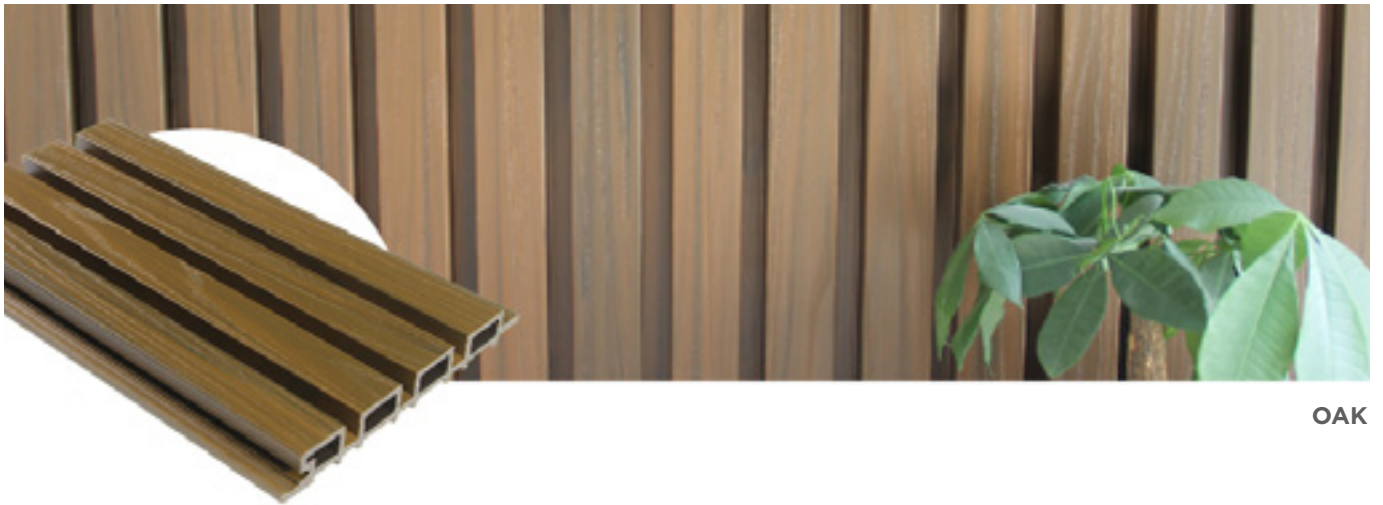

OAK



ASH GREY

FOR MORE INFORMATION

For more information on composite batten cladding or our other products
visit www.bisonsystems.co.uk
Tel: 01342 337 160 email: info@bisonsystems.co.uk



The mark of
responsible forestry

